

NOTES:
 This drawing is the copyright of Dublin City Council. It must not be copied or reproduced without written consent. Only figured dimensions are to be taken from this drawing. All contractors must visit the site and be responsible for taking and checking all dimensions related to the works shown on this drawing.

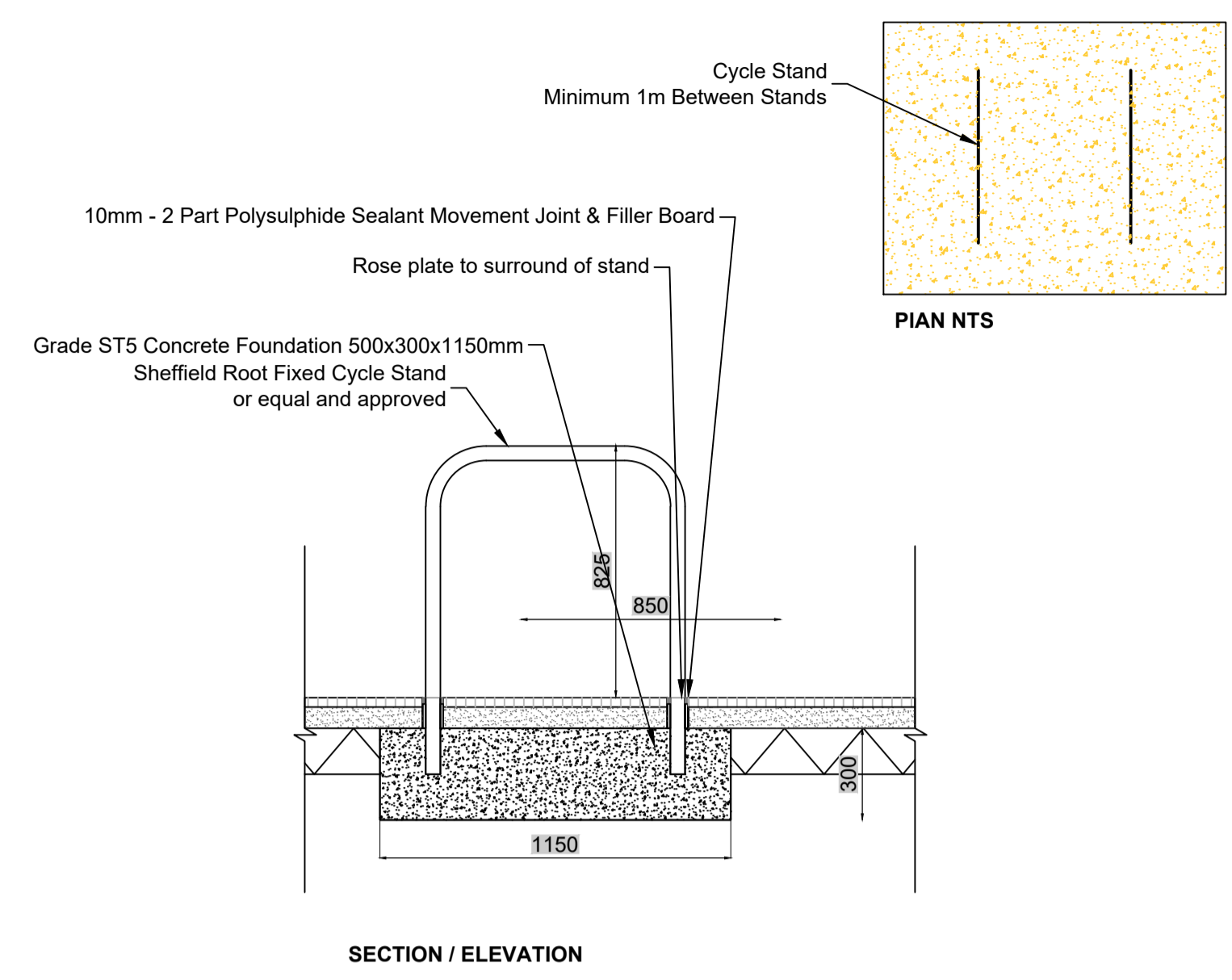

01 CYCLE STAND
 SCALE: 1:20 @ A1

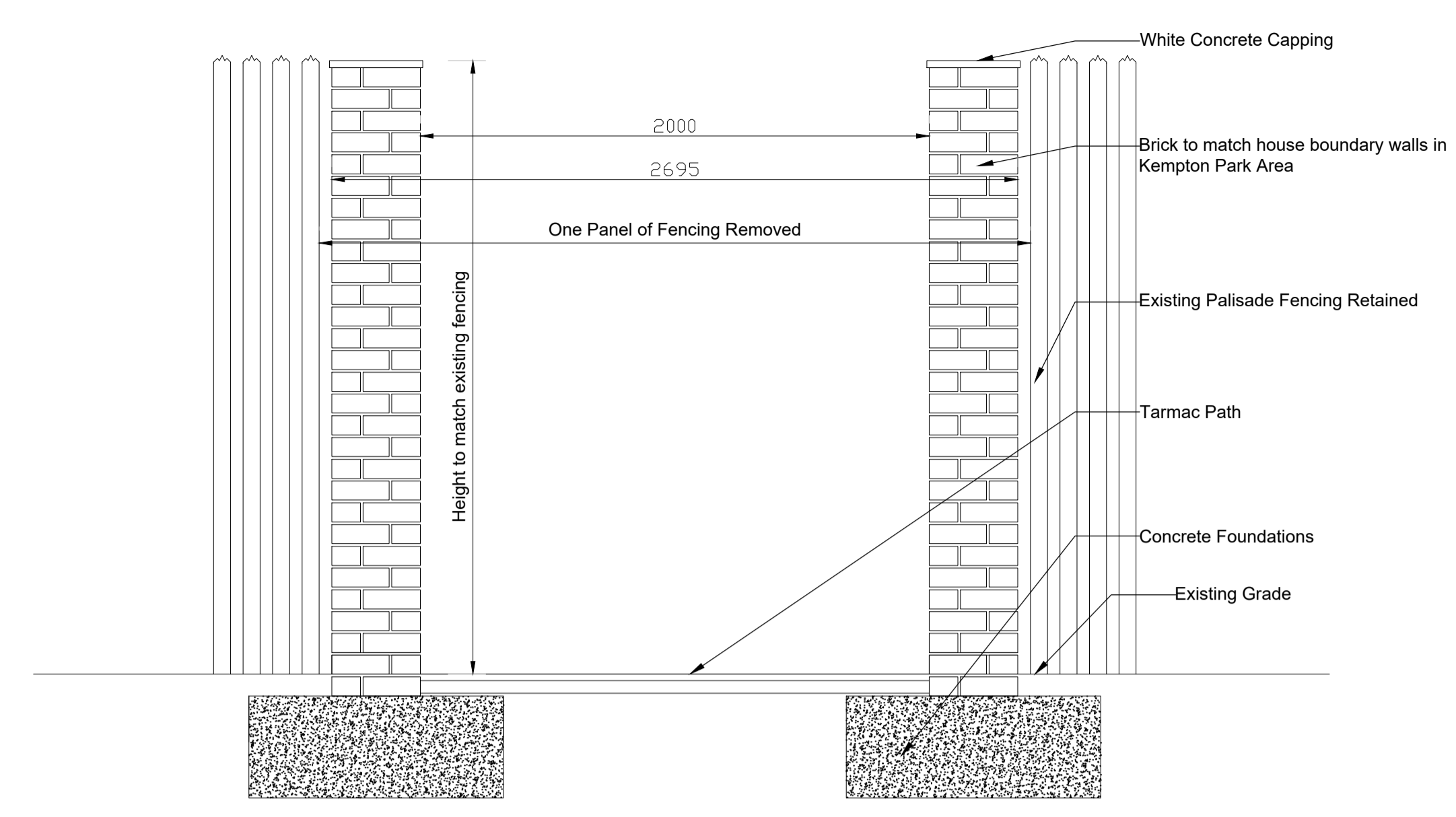

02 PARK ENTRANCE KEMPTON
 SCALE: 1:20 @ A1

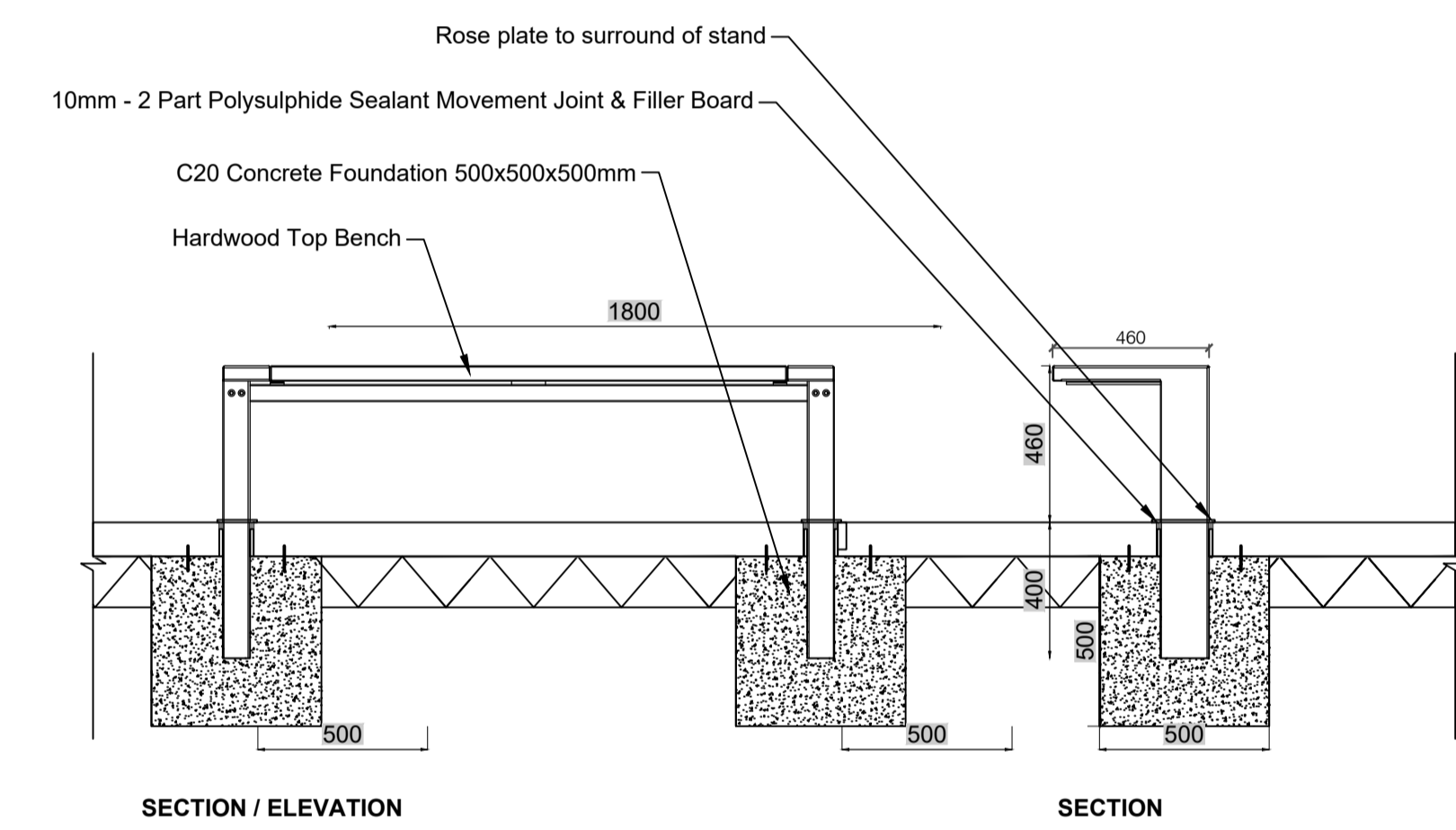

03 Bench / Seat Detail
 SCALE: 1:20 @ A1

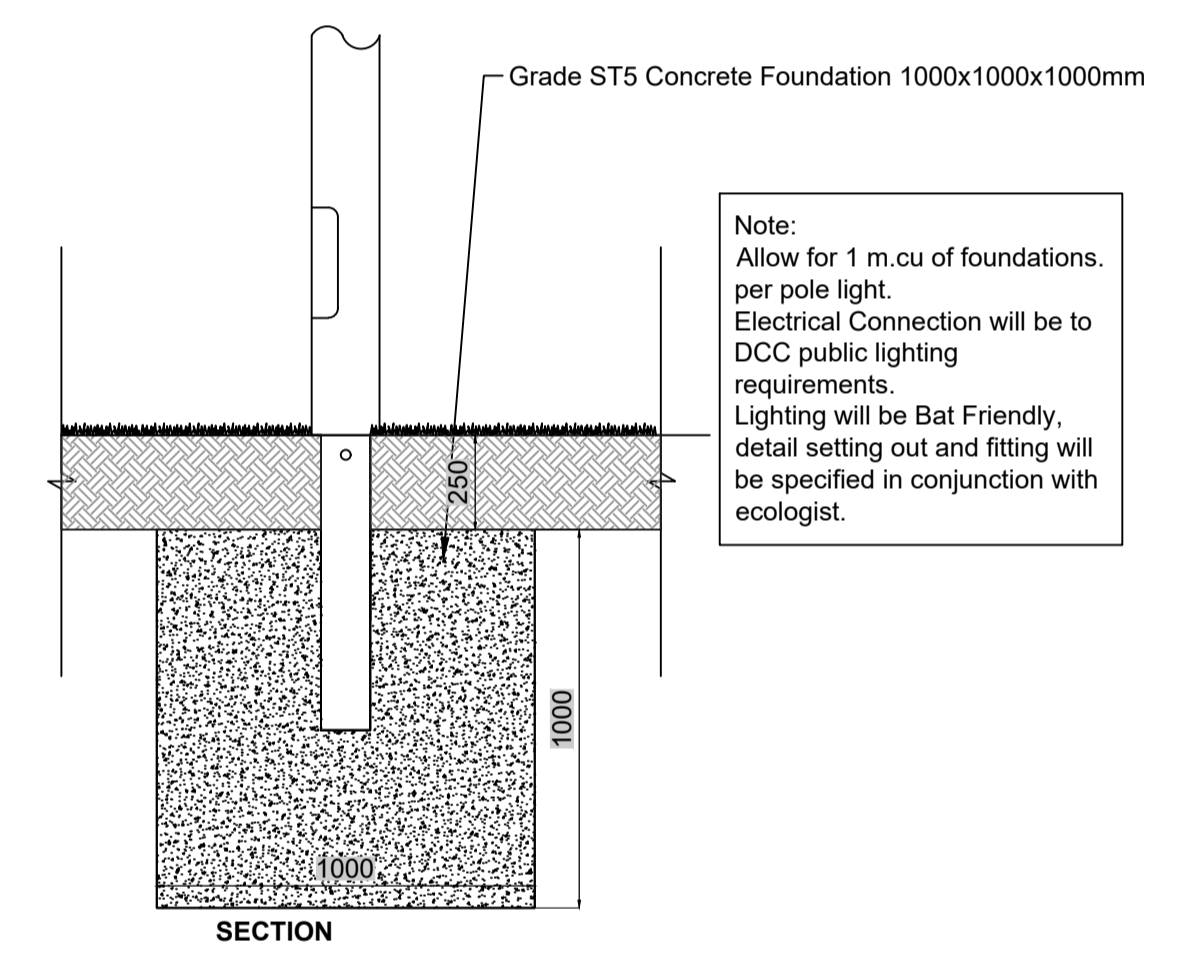

04 PATH POLE LIGHT
 SCALE: 1:20 @ A1

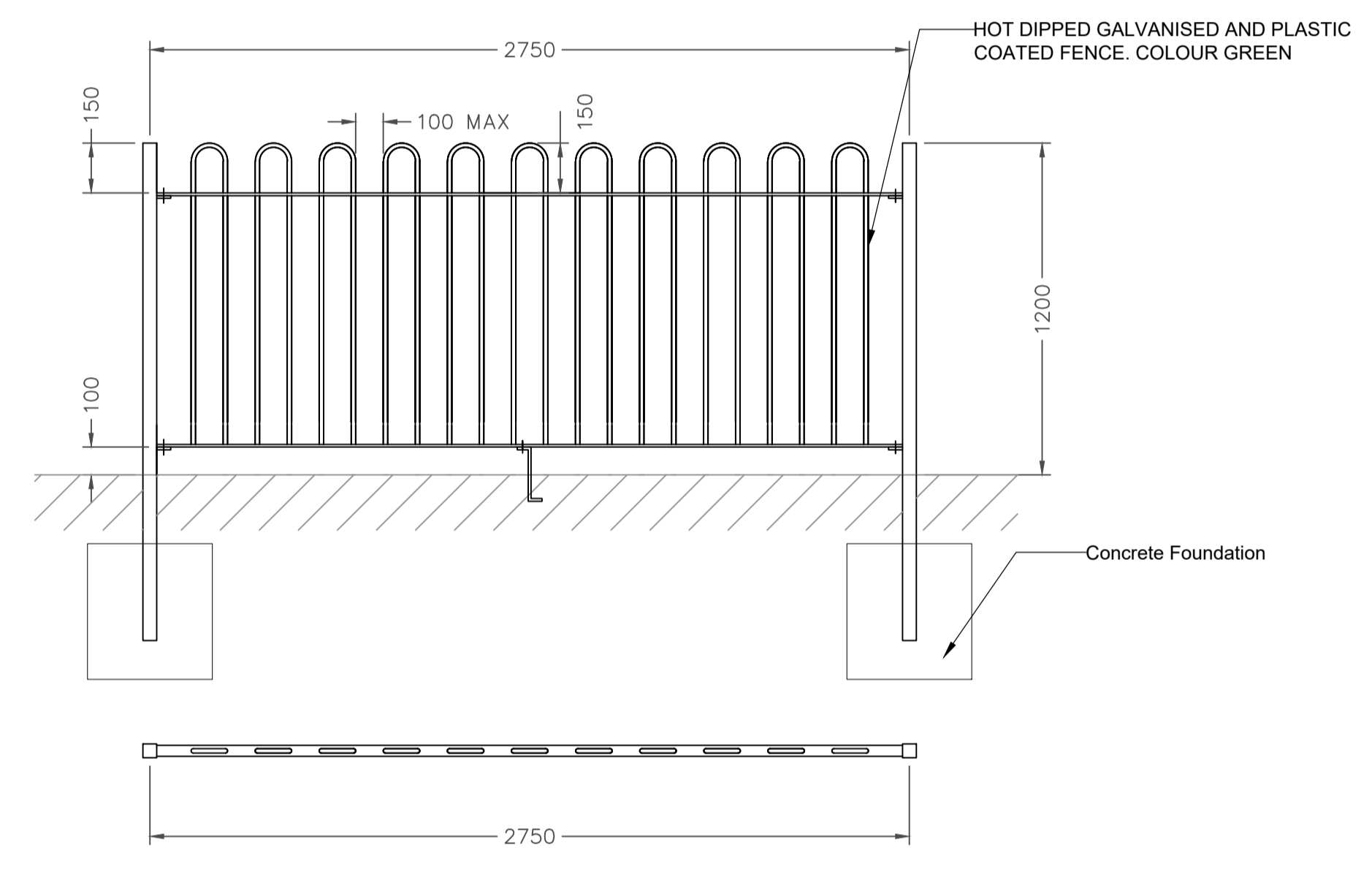

05 BOW TOP FENCE DETAIL (Play Area)
 SCALE: 1:20 @ A1

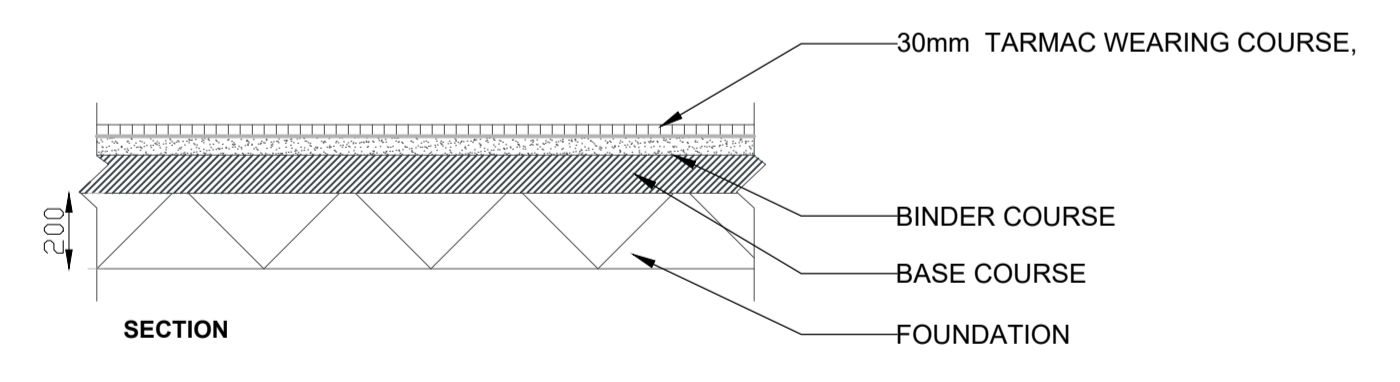

06 TARMAC DETAIL
 SCALE: 1:20 @ A1

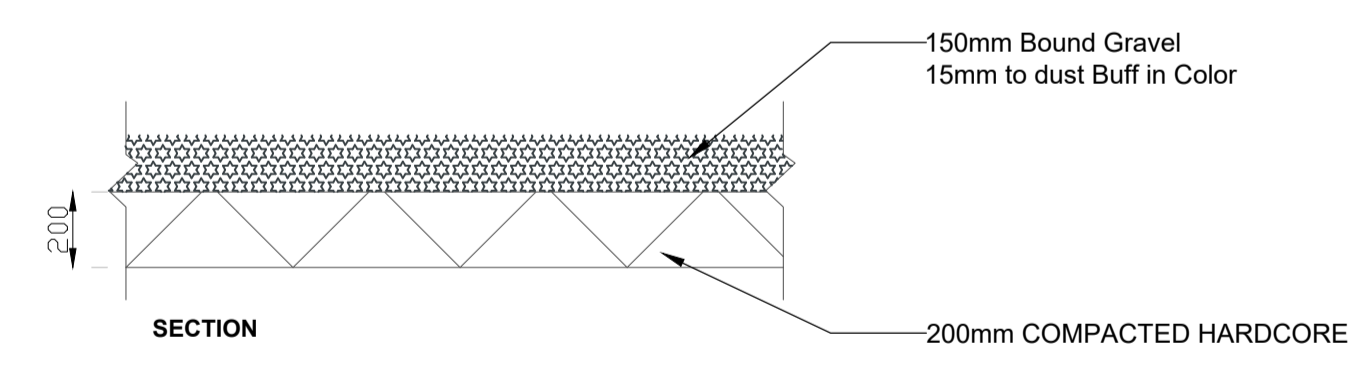

07 SELF BOUND GRAVEL
 SCALE: 1:20 @ A1

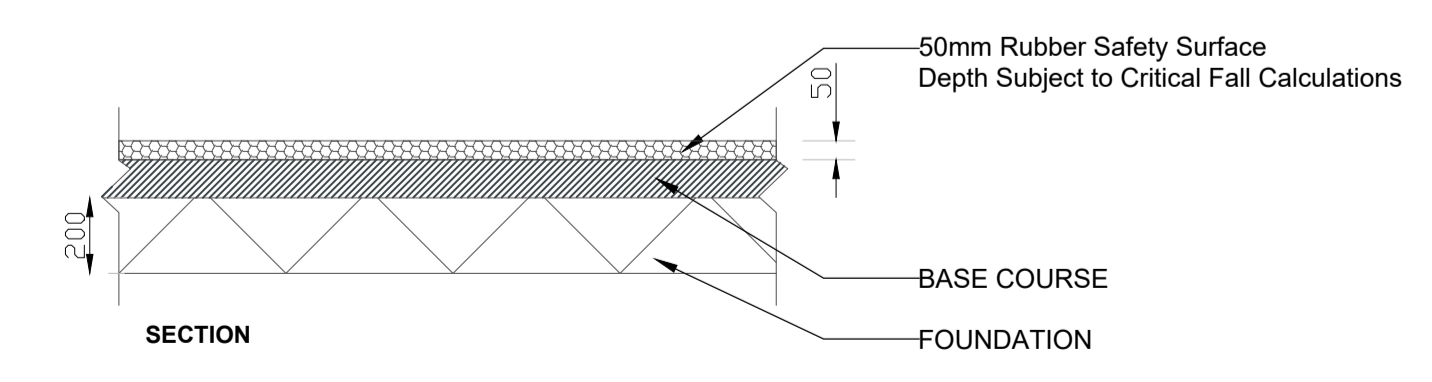

08 SAFETY SURFACE DETAIL
 SCALE: 1:20 @ A1

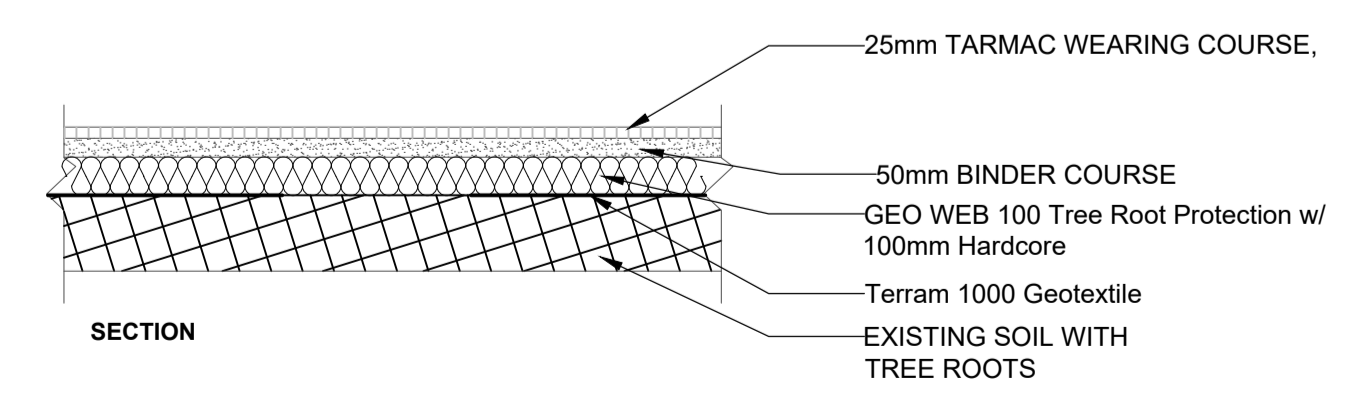

09 PATHS OVER ROOTS
 SCALE: 1:20 @ A1

Part 8 Issue

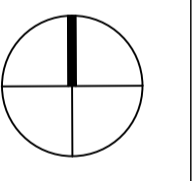

PROJECT
Martin Savage Park

SUBJECT
DETAILS SHEET 4

DATE	Oct 2023	DRAWN BY	EO'G
SCALE	AS @ A1	CHECKED BY	LM
DRAWING NUMBER	MSP-LA-DL-303	REVISION	-
Project Number	000	Status	B
A - PRELIMINARY	B - ISSUED FOR PLANNING	C - ISSUED FOR DESIGN INFORMATION	D - ISSUED FOR TENDER
E - ISSUED FOR APPROVAL	F - ISSUED FOR CONSTRUCTION	G - AS BUILT	

Last saved by: 42942/2023-11-13, Last Priced: 2023-11-13
 Filename: C:\USERS\2942\ONE\DRIVE - DUBLIN CITY COUNCIL\DOCUMENTS\MARTIN SAVAGE PARK\CAD\SHETS\603080-LA-DL-303.DWG