

NO PART OF THIS DRAWING MAY BE REPRODUCED OR TRANSMITTED IN ANY FORM OR STORED IN ANY RETRIEVAL SYSTEM OF ANY NATURE WITHOUT THE WRITTEN PERMISSION OF MALONE O'REGAN CONSULTING ENGINEERS AS COPYRIGHT HOLDER EXCEPT AS AGREED FOR USE ON THE PROJECT FOR WHICH THE DRAWING WAS ORIGINALLY CREATED.

THIS DRAWING TO BE READ IN CONJUNCTION WITH ALL OTHER RELEVANT DRAWINGS, SPECIFICATIONS AND THE PRELIMINARY HEALTH & SAFETY PLAN.

ALL DIMENSIONS ARE IN mm UNLESS NOTED OTHERWISE. DO NOT SCALE DIMENSIONS.

THE CONTRACTOR SHALL CHECK ALL DIMENSIONS PRIOR TO THE COMMENCEMENT OF CONSTRUCTION. ALL DISCREPANCIES SHALL BE REPORTED TO THIS OFFICE IN WRITING.

NOTES

BY	DRAWING No. & REFERENCE	DATE
SURVEY	J62660 COLLINS AVE TOPO 29023 20	29.09.2023
ARCH	SHB4-CAD-222-M2-CDA-AR-SITEWORKS	15.04.2024
LS ARCH	SHB4-CAD-DR-MAL-L-PT-0001 REV 0	17.04.2024

VEHICLE SWEEP PATH LEGEND

- SATISFACTORY SATISFACTORY: SWEEP PATH WORKS WITH CURRENT LAYOUT
- FEASIBLE FEASIBLE: SLIGHT DIFFICULTIES BUT SWEEP PATH COULD WORKS WITH MINOR LAYOUT MODIFICATIONS
- NOT ACCEPTABLE NOT ACCEPTABLE: SWEEP PATH NOT POSSIBLE WITH LAYOUT AND SIGNIFICANT ALTERATION REQUIRED
- SOLID HATCH INDICATES FORWARD MOTION OF THE VEHICLE
- LINED HATCH INDICATES REVERSE MOTION OF THE VEHICLE

- *N.B.
- COLOUR OF SOLID/LINED HATCHES IN LEGEND TO MATCH RELEVANT COLOUR OF THE AUTO-TRACK IN THE DRAWING (i.e. IF SWEEP PATH IS A SATISFACTORY GREEN THEN SO WILL HATCHES BE SHOWN AS ABOVE)
 - OVERALL GRASS HATCHING SHOWN AS LIGHT GRAY TO AVOID CONFUSION WITH SWEEP PATHS (AS SHOWN BELOW)

GRASS HATCHING

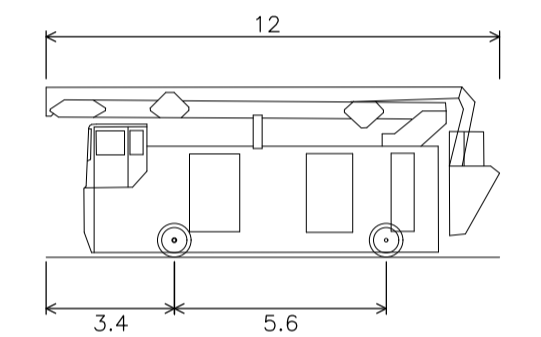

AERIAL PLATFORM/ TURNTABLE LADDER/ SPECIAL APPLIANCE

OVERALL LENGTH	12.000M
OVERALL WIDTH OVERALL	2.550M
BODY HEIGHT	4.500M
MIN BODY GROUND CLEARANCE	0.130M
TRACK WIDTH	2.550M
LOCK-TO-LOCK TIME	4.00S
CURB TO CURB TURNING RADIUS	13.750M

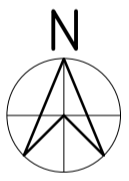

3	ISSUED FOR PLANNING	23.07.24	KD	DW
2	RED LINE SITE BOUNDARY REVISED	25.04.24	KD	DW
1.1	SITE LAYOUT REVISED TO SUIT LATEST LANDSCAPE ARCH LAYOUT	18.04.24	KD	DW
1	SITE LAYOUT REVISED TO SUIT LATEST ARCH LAYOUT AND COMMENTS	16.04.24	KD	DW
0	ISSUED FOR INFORMATION	22.03.24	KD	PB
REV	DESCRIPTION	DATE	BY	CHK

STATUS: **P3 – PLANNING**

MOR MALONE O'REGAN CONSULTING ENGINEERS

Unit 2B Richview Office Park, Clonskeagh, DUBLIN 14 D14 XT57

T: +353 1 260 2655
E: dublin@mor.ie
W: www.maloneoregan.ie

Offices also in:
GALWAY T: +353 91 531 069 E: galway@mor.ie
WATERFORD T: +353 51 876 855 E: waterford@mor.ie

CLIENT: DUBLIN CITY COUNCIL

JOB NAME: SOCIAL HOUSING PPP BUNDLE 4 (SHB4) COLLINS AVENUE

DRG. NAME: SWEPT PATH ANALYSIS AERIAL PLATFORM SPECIAL APPLIANCE

JOB REF	SHEET	SCALE	DATE	BY	ENG	APP	REV.
23006	A1	1:500	SEPT'2023	KD	PB	PB	3

DRG. NO.: SHB4-CAD-DR-MOR-CS-P3-112