

NO PART OF THIS DRAWING MAY BE REPRODUCED OR TRANSMITTED IN ANY FORM OR STORED IN ANY RETRIEVAL SYSTEM OF ANY NATURE WITHOUT THE WRITTEN PERMISSION OF MALONE O'REGAN CONSULTING ENGINEERS AS COPYRIGHT HOLDER EXCEPT AS AGREED FOR USE ON THE PROJECT FOR WHICH THE DRAWING WAS ORIGINALLY CREATED.

THIS DRAWING TO BE READ IN CONJUNCTION WITH ALL OTHER RELEVANT DRAWINGS, SPECIFICATIONS AND THE PRELIMINARY HEALTH & SAFETY PLAN.

ALL DIMENSIONS ARE IN mm UNLESS NOTED OTHERWISE. DO NOT SCALE DIMENSIONS.

THE CONTRACTOR SHALL CHECK ALL DIMENSIONS PRIOR TO THE COMMENCEMENT OF CONSTRUCTION. ALL DISCREPANCIES SHALL BE REPORTED TO THIS OFFICE IN WRITING.

NOTES

BY	DRAWING No. & REFERENCE	DATE
SURVEY		
ARCH	SHB4-CVD-222-M2-COA-AR-SITWORKS	20/10/2023

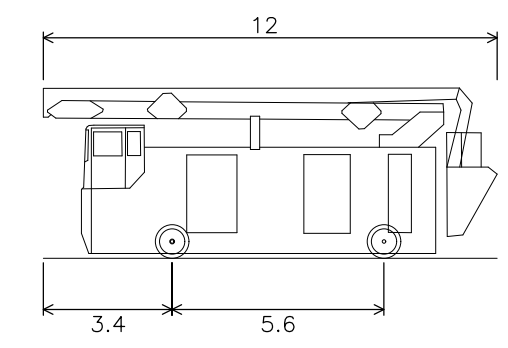

AERIAL PLATFORM/ TURNTABLE LADDER/ SPECIAL APPLIANCE

OVERALL LENGTH	12.000M
OVERALL WIDTH	2.500M
BODY HEIGHT	4.500M
MIN BODY GROUND CLEARANCE	0.130M
TRACK WIDTH	2.500M
LOCK-TO-LOCK TIME	4.00S
CURB TO CURB TURNING RADIUS	13.750M

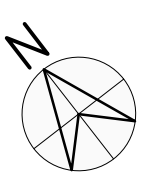

00	ISSUED FOR PLANNING (PART B)	12.07.24	JD	CC
----	------------------------------	----------	----	----

REV	DESCRIPTION	DATE	BY	CHK

STATUS: P3 - ISSUED FOR PLANNING

**MDR**  
 MALONE O'REGAN  
 CONSULTING ENGINEERS

Unit 2B Richview Office Park,  
 Clonskeagh,  
 DUBLIN 14  
 D14 XT57

T: +353 1 260 2655  
 E: dublin@moroe.ie  
 W: www.maloneoregan.ie

Offices also in:  
 GALWAY T: +353 91 531 069 E: galway@moroe.ie  
 WATERFORD T: +353 51 876 855 E: waterford@moroe.ie

CLIENT: NATIONAL DEVELOPMENT FINANCE AGENCY AND DUBLIN CITY COUNCIL

JOB NAME: SOCIAL HOUSING BUNDLE 4, DEVELOPMENT AT CROKE VILLAS, SACKVILLE AVENUE.

DRG. NAME: SWEEP PATH ANALYSIS AERIAL PLATFORM SPECIAL APPLICATION

JOB REF	SHEET	SCALE	DATE	BY	ENG	APP	REV.
23006	A1	1:250	JULY 2023	JD	CC	COB	00

DRG. NO.: SHB4-CVD-DR-MOR-CS-P3-111

R:\2023\23006\B4-Croke Villas\07 Design And Drawings\01 Drawings\PL - Planning\SHB4-CVD-DR-MOR-CS-P3-111 - Sweep Path Analysis Special Application.dwg