

NO PART OF THIS DRAWING MAY BE REPRODUCED OR TRANSMITTED IN ANY FORM OR STORED IN ANY RETRIEVAL SYSTEM OF ANY NATURE WITHOUT THE WRITTEN PERMISSION OF MALONE O'REGAN CONSULTING ENGINEERS AS COPYRIGHT HOLDER EXCEPT AS AGREED FOR USE ON THE PROJECT FOR WHICH THE DRAWING WAS ORIGINALLY CREATED.

THIS DRAWING TO BE READ IN CONJUNCTION WITH ALL OTHER RELEVANT DRAWINGS, SPECIFICATIONS AND THE PRELIMINARY HEALTH & SAFETY PLAN.

ALL DIMENSIONS ARE IN mm UNLESS NOTED OTHERWISE. DO NOT SCALE DIMENSIONS.

THE CONTRACTOR SHALL CHECK ALL DIMENSIONS PRIOR TO THE COMMENCEMENT OF CONSTRUCTION. ALL DISCREPANCIES SHALL BE REPORTED TO THIS OFFICE IN WRITING.

NOTES

BY	DRAWING No. & REFERENCE	DATE
SURVEY		
ARCH	SHB4-CAF-DR-SHA-AP-P3-0008 R03	30.05.2024
LS ARCH	SHB5-CAF-DR-MA-L-P1-0001-P07	28.02.2024

VEHICLE SWEEP PATH LEGEND

- SATISFACTORY: SWEEP PATH WORKS WITH CURRENT LAYOUT
- FEASIBLE: SLIGHT DIFFICULTIES BUT SWEEP PATH COULD WORKS WITH MINOR LAYOUT MODIFICATIONS
- NOT ACCEPTABLE: SWEEP PATH NOT POSSIBLE WITH LAYOUT AND SIGNIFICANT ALTERATION REQUIRED
- SOLID HATCH INDICATES FORWARD MOTION OF THE VEHICLE
- LINED HATCH INDICATES REVERSE MOTION OF THE VEHICLE

*N.B. COLOUR OF SOLID/LINED HATCHES IN LEGEND TO MATCH RELEVANT COLOUR OF THE AUTO-TRACK IN THE DRAWING (i.e. IF SWEEP PATH IS A SATISFACTORY GREEN THEN SO WILL HATCHES BE SHOWN AS ABOVE)

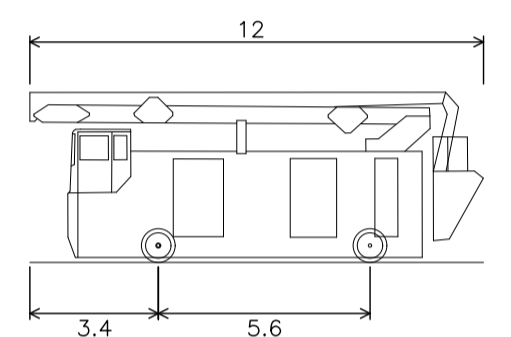

AERIAL PLATFORM/ TURNTABLE LADDER/ SPECIAL APPLIANCE

OVERALL LENGTH	12.000M
OVERALL WIDTH OVERALL	2.550M
BODY HEIGHT	4.500M
MIN. BODY GROUND CLEARANCE	0.130M
TRACK WIDTH	2.550M
LOCK-TO-LOCK TIME	4.00S
CURB TO CURB TURNING RADIUS	13.750M



5	UPDATED ARCHITECT LAYOUT	12.06.24	DK	ND
4	UPDATED ARCHITECT LAYOUT	05.06.24	KD	ND
3	SWEEP PATH REVISED TO AVOID CLASH WITH FOOTPATH	12.04.24	KD	ND
2	ROAD CROSSING REMOVED AND REDLINE BOUNDARY REVISED AS PER ARCHITECT LATEST LAYOUT	26.03.24	KD	PB
1	REVISED AS PER NEW SITE LAYOUT	28.02.24	KA	PB
0	ISSUED FOR INFORMATION	17.01.24	KD	PB

REV DESCRIPTION DATE BY CHK

STATUS

P3 – PLANNING

Unit 2B Richview Office Park,
Clonskeagh,
DUBLIN 14
D14 XT57

T: +353 1 260 2655
E: dublin@morce.ie
W: www.maloneoregan.ie

Offices also in:
GALWAY T: +353 91 531 069 E: galway@morce.ie
WATERFORD T: +353 51 876 855 E: waterford@morce.ie

CLIENT
NDFA

JOB NAME
CHURCH OF THE ANNUNCIATION

DRG. NAME
SWEEP PATH ANALYSIS
AERIAL PLATFORM SPECIAL APPLIANCE

JOB REF	SHEET	SCALE	DATE	BY	ENG	APP	REV.
23006	A1	1:250	JULY 2023	KD	PB	PB	5

DRG. NO.
SHB4-CAF-DR-MOR-CS-P3-113

